

STRADDLE STACKER  
**TASKCONDA**

SALES BROCHURE



**FORKLIFT SALES, SERVICE & RENTALS**



[TASKFORKLIFTS.COM.AU](http://TASKFORKLIFTS.COM.AU)



[SALES@TASKAUSTRALIA.COM.AU](mailto:SALES@TASKAUSTRALIA.COM.AU)



CALL US: 1300 13 2002

# + TASKCONDA<sup>®</sup>

## STRADDLE STACKER



1500kg  
Capacity.



Up to 4.5m  
Lift Height.



Power  
Steering.



No License  
Required.



Integrated  
Tilting Carriage.



Integrated  
Side-shift.

### COMPACT & EASY TO USE.

The CONDA<sup>®</sup> pedestrian stacker is designed for indoor use and perfect for a wide variety of applications such as workshops, warehouses and storage centers.

Operators find the CONDA<sup>®</sup> pedestrian stacker a compact, simple and easy to use. The electronic power steering allows users to work in very narrow aisle spacings; and the optional three stage "full free lift" mast is an ideal solution for users working within tight height restrictions.

The unit comes as standard with a tilting carriage and side-shift allowing operators to maneuver pallets and materials safer, and more efficiently.



### CURTIS<sup>®</sup> CONTROLLED.

The Curtis<sup>®</sup> Programmable Control System with Multi-mode allows infinite control of all machine functions.



Authorised TASK<sup>®</sup> support technicians are able adjust and optimise settings to meet environmental requirements or different operator skill levels.

# TASKCONDA<sup>®</sup>

## STRADDLE STACKER

EMAIL: SALES@TASKAUSTRALIA.COM.AU

WEB: TASKFORKLIFTS.COM.AU

CALL US: 1300 13 2002

• ADELAIDE • SYDNEY • MELBOURNE • BRISBANE • SINGAPORE • SHANGHAI • DALLAS •

# + TASKCONDA<sup>®</sup>

## STRADDLE STACKER



Large Industrial Battery



Single-Point Battery Filling



240v Internal Charger



Latest Curtis Controller



TASK Genuine Parts Availability

**1year**  
Unlimited Hours  
Warranty

Manufacturers Warranty

### STANDARD FEATURES.

- 1500kg Capacity
- 2.5m - 4.5m Lifting Height
- Two stage and Three Stage Mast Configurations
- Full Free Lift Available
- Intelligent AC Drive Motor
- Tilting Carriage as standard
- Integrated Side-Shift as standard
- Responsive Electric Power Steering
- American Designed Curtis Controller
- TASK Transmission
- Single Point Battery Filling System Included
- Super Quiet Drive Motor
- Built and Tested to Exceed Australian Standards
- 1-year, Unlimited Hours Warranty
- Emergency Stop Button for Increased Safety

# TASKCONDA<sup>®</sup>



### OPTIONAL EXTRAS.



Digital Weight Gauge



Different Length Tines



Special Build Options Available



TASK x NEXSYS  
Battery Upgrade

STRADDLE  
STACKER

EMAIL: SALES@TASKAUSTRALIA.COM.AU

WEB: TASKFORKLIFTS.COM.AU

CALL US: 1300 13 2002

• ADELAIDE • SYDNEY • MELBOURNE • BRISBANE • SINGAPORE • SHANGHAI • DALLAS •



2.5 - 4.5m  
Lift Height



1500 Kgs  
Capacity



Integrated  
Tilt Carriage



Side-shift as  
Standard

## TECHNICAL INFO

	TWO STAGE				THREE STAGE
Lift height metres	2.5	3.0	3.5	4.0	4.5 Tri
A. Rated capacity at 600mm I.C. Kg	1500	1500	1500	1500	1000
B. Lift height mm	2500	3000	3500	4000	4500
C. Extended height mm with load backrest	3660	4160	4660	5160	5660
D. Collapsed height mm	1770	2020	2270	2520	2040
E. Free lift mm	350				1435
F. Chassis length mm to face of forks	770				930
G. Chassis width mm	820				
H. Wheelbase mm	1342				1538
I. Carriage width mm	815				
J. Chassis under clearance mm	50				
K. Turning radius mm	1722				
L. Straddle I.D/ O.D mm.	1220 / 1370 Or 1270 / 1420				
M. Weight less battery kg	740	760	780	800	1355
N. Battery compartment size mm	795mm x 188mm x 570mm high				
O. Right angle stacking aisle mm	Dimension F + Load length + 100 mm				

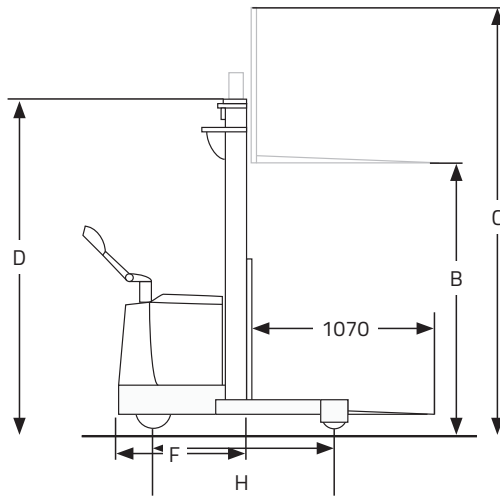

CONDA Technical Drawing

