

STRADDLE STACKER
TASKPYTHON

SALES BROCHURE



FORKLIFT SALES, SERVICE & RENTALS



TASKFORKLIFTS.COM.AU



SALES@TASKAUSTRALIA.COM.AU



CALL US: 1300 13 2002

+ TASKPYTHON® HEAVY DUTY STRADDLE STACKER

HEAVY DUTY STACKER.

The PYTHON® Heavy Duty pedestrian stacker is available in capacities up to 2000kgs, making the PYTHON pedestrian stacker a true 2 tonne unit.

The electronic power steering makes the PYTHON a simple, easy to operate stacker; the optional three stage "full free lift" mast is an ideal solution for users working within tight height restrictions.

Additional options of a tilting carriage and side-shift will allow operators to maneuverer pallets and materials safer, and more efficiently.

INDUSTRY READY.

The PYTHON® is supplied with a 290AH industrial battery, with optional upgrades to the larger 510AH industrial battery. - This allows operators multiple shift use before needing to recharged the unit.

All the functions including lift and lower are controlled using Task's VTC (Variable Total Control) module. This provides users with absolute control when operating the PYTHON.



TASKPYTHON®

STRADDLE
STACKER

CURTIS® CONTROLLED.

The Curtis® Programmable Control System with Multi-mode allows infinite control of all machine functions.



Authorised TASK® support technicians are able adjust and optimise settings to meet environmental requirements or different operator skill levels.



2.5 - 6.0m
Lift Height



1500 - 2000
KGs Capacity



Heavy Duty
Stacker

TECHNICAL INFO

	MODEL	TWO STAGE				THREE STAGE			
Lift height metres		2.5	3.0	3.5	4.0	3.7	4.5	5.2	6.0
A. Rated capacity at 600mm I.C. Kg	1.5	1500	1500	1500	1500	1500	1500	1300	N/A
	2.0	2000	2000	2000	2000	2000	2000	1800	1500
B. Lift height mm		2500	3000	3500	4000	3700	4500	5200	6000
C. Extended height mm with load backrest		3650	4150	4650	5150	4950	5750	6450	7250
D. Collapsed height mm	1.5	1770	2020	2270	2520	1790	2040	2290	N/A
	2.0	1800	2050	2300	2550	1830	2080	2330	2580
E. Free lift mm		NIL				1250	1500	1750	2000
F. Chassis length mm to face of forks	1.5	1010				1035			
	2.0	1050				1075			
G. Chassis width mm		915							
H. Wheelbase mm	1.5	1430				1455			
	2.0	1470				1495			
I. Carriage width mm		815							
J. Chassis under clearance mm		50							
K. Turning radius mm	1.5	1690				1715			
	2.0	1730				1755			
L. Straddle I.D / O.D mm	1.5	1220 / 1420 or 1270 / 1470							
	2.0	1220 / 1425 or 1270 / 1475							
M. Weight with battery kg	1.5	1150	1180	1210	1240	1270	1310	1350	N/A
	2.0	1360	1400	1440	1480	1550	1640	1730	1820
N. Battery compartment size mm	Standard	885mm Wide X 190mm Long X 600mm High							
	Optional	800mm Wide X 340mm Long X 600mm High							
O. Right angle stacking aisle mm		Dimension F + Load Length + 150 mm							

Due to continuous product improvement, specifications are subject to change without notice or obligation. Some systems and features shown are optional at extra cost.



2.5 - 6.0m
Lift Height



1500 - 2000
KGs Capacity



Heavy Duty
Stacker

TECHNICAL INFO

 PYTHON Technical Drawing

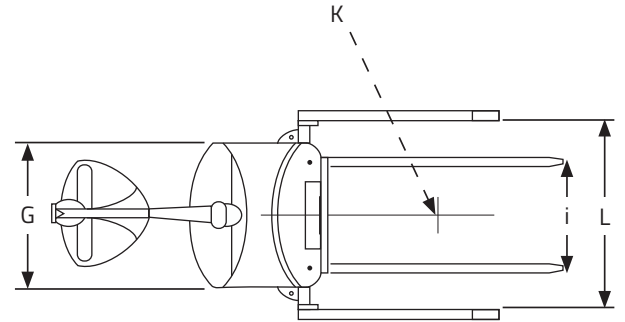
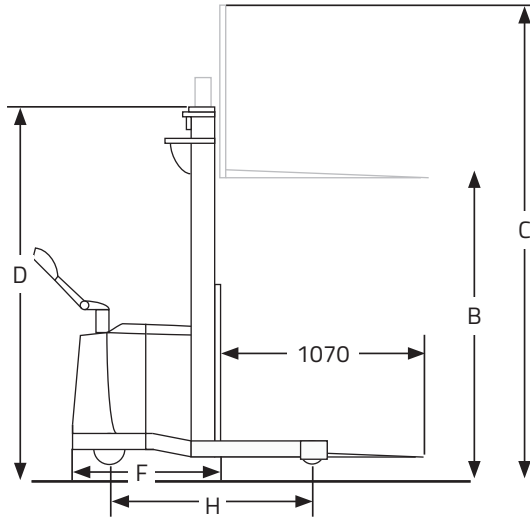

TASKPYTHON[®]

STRADDLE
STACKER

Due to continuous product improvement, specifications are subject to change without notice or obligation. Some systems and features shown are optional at extra cost.

EMAIL: SALES@TASKAUSTRALIA.COM.AU

WEB: TASKFORKLIFTS.COM.AU

CALL US: 1300 13 2002

• ADELAIDE • SYDNEY • MELBOURNE • BRISBANE • SINGAPORE • SHANGHAI • DALLAS •