

HEAVY DUTY LEGLESS STACKER
TASKCOBRA

SALES BROCHURE



FORKLIFT SALES, SERVICE & RENTALS



TASKFORKLIFTS.COM.AU



SALES@TASKAUSTRALIA.COM.AU



CALL US: 1300 13 2002

+ TASK COBRA®

HEAVY DUTY LEGLESS® STACKER



2.5-6.0m
Lift Height.



1300 - 2000kg
Capacity.



Integrated
Tilting Mast.



Responsive
Power Steering.



Integrated
Side-Shift



Heavy-duty
Legless Stacker

POWERFUL LEGLESS® STACKER.

The COBRA® Heavy Duty Legless stacker is available in capacities up to 2000kgs, making the COBRA Legless stacker a true 2 tonne unit.

The electronic power steering makes the COBRA a simple and easy to operate; the recommended three stage "full free lift" mast is an ideal solution for users working within tight height restrictions. The unit comes as standard with a tilting mast and side-shift allowing operators to maneuver pallets and materials safely, and more efficiently.

The COBRA® Heavy Duty Legless stacker is equipped with a range of safety features to ensure maximum safety. These include an emergency stop button that is easily accessible, an electronic dead-man brake that engages when the handle is fully raised or lowered, and a high/low speed switch conveniently located on the dashboard.

Additionally, the machine is fitted with Anti-roll back on ramps, an emergency belly button to prevent operator crush injuries, and a handle-mounted horn for added safety measures.

CURTIS® CONTROLLED.



The Curtis® Programmable Control System with Multi-mode allows infinite control of all machine functions.

Authorised TASK® support technicians are able adjust and optimise settings to meet environmental requirements or different operator skill levels.

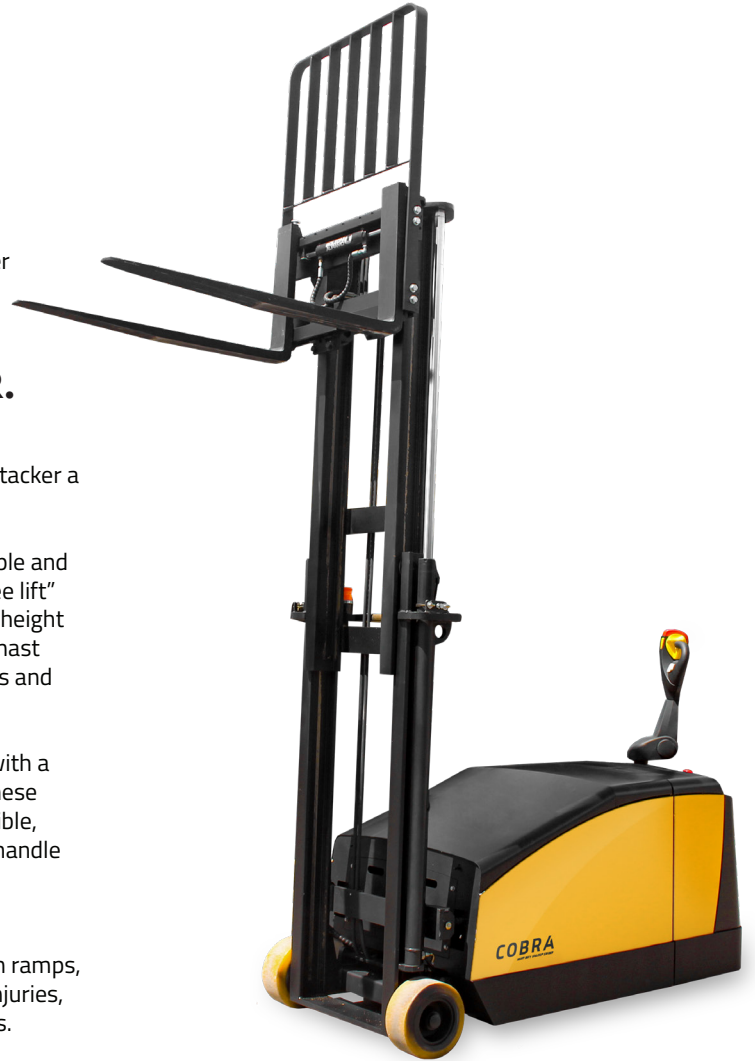

TASK COBRA®

LEGLESS STACKER

EMAIL: SALES@TASKAUSTRALIA.COM.AU

WEB: TASKFORKLIFTS.COM.AU

CALL US: 1300 13 2002

• ADELAIDE • SYDNEY • MELBOURNE • BRISBANE • SINGAPORE • SHANGHAI • DALLAS •

+ TASK COBRA®

HEAVY DUTY LEGLESS STACKER



Flashing Safety Light



Single-Point Battery Filling



Variable Total Control



Latest Curtis® Controller



TASK® Genuine Parts Availability



Manufacturers Warranty

STANDARD FEATURES.

- 1300kg and 2000kg Capacity
- 2.5m - 6.0m Lifting Height
- Two stage and three stage mast configurations
- Full Free Lift Available with 3-stage mast configuration
- Intelligent AC Drive Motor
- Tilting Mast as standard
- Side-shift function as standard
- Responsive Power Steering
- Variable Total Control for precise handling
- American Designed Curtis® Controller
- AC TASK® Transmission
- Single Point Battery Filling System Included
- Super Quiet Drive Motor
- Built and Tested to Exceed Australian Standards
- 1-year, Unlimited Hours Warranty
- Emergency Stop Button for Increased Safety

TASK COBRA®



OPTIONAL EXTRAS.



Digital Weight Gauge



Different Length Tines



Special Build Options Available



Nexsys® Battery Upgrade

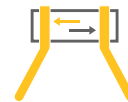

Side-Shift Fork Positioner

LEGLESS
STACKER

EMAIL: SALES@TASKAUSTRALIA.COM.AU

WEB: TASKFORKLIFTS.COM.AU

CALL US: 1300 13 2002

• ADELAIDE • SYDNEY • MELBOURNE • BRISBANE • SINGAPORE • SHANGHAI • DALLAS •

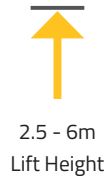

TECHNICAL INFO

LIFT HEIGHT METRES	MAST	TWO STAGE						THREE STAGE			
	MODEL	2.5	3.0	3.5	4.0	4.5	5.0	3.7 TRI	4.5 TRI	5.2 TRI	6.0 TRI
A. RATED CAPACITY AT 600mm L.C. kg	1.3	1300	1300	1300	1250	1050	850	1200	950	750	N/A
	1.5	1500	1500	1500	1500	1250	1000	1500	1250	1000	N/A
	2.0	2000	2000	2000	2000	1750	1500	2000	1750	1500	1300
B. LIFT HEIGHT mm		2500	3000	3500	4000	4500	5000	3700	4500	5200	6000
C. EXTENDED HEIGHT mm WITH LOAD BACK REST		3650	4150	4650	5150	5650	6150	4950	5750	6450	7250
D. COLLAPSED HEIGHT mm		1780	2030	2280	2530	2780	3030	1830	2080	2330	2580
E. FREE LIFT mm		NIL						1250	1500	1750	2000
F. CHASSIS LENGTH mm (TO FACE OF FORKS)	1.3	1590									
	1.5	1756									
	2.0	1928				1960					
G. CHASSIS WIDTH mm		930									
G1. LOAD WHEEL WIDTH mm	1.3	930									
	1.5	930									
	2.0	930			1060			1060	1060	1060	1060
H. WHEELBASE mm	1.3	1115									
	1.5	1280									
	2.0	1445			1500						
I. CARRIAGE WIDTH mm		815									
J. CHASSIS UNDER CLEARANCE mm		105									
K. TURNING RADIUS mm	1.3	1390									
	1.5	1540									
	2.0	1800									
L. REAR TILT (DEGREES)		9									
M. FORWARD TILT (DEGREES)		3									
P. WEIGHT LESS BATTERY kg* (Approx - to be confirmed)	1.3	2140	2170	2220	2230	2260	2290	2430	2460	2490	N/A
	1.5	2220	2250	2280	2310	2340	2370	2480	2510	2540	N/A
	2.0	2800	2840	2880	2920	2960	3000	3120	3180	3240	3300
Q. BATTERY COMPARTMENT SIZE mm		800 WIDE x 340 LONG x 600 HIGH									
R. RIGHT ANGLE STACKING AISLE mm		DIMENSION F PLUS LOAD LENGTH PLUS 150mm									

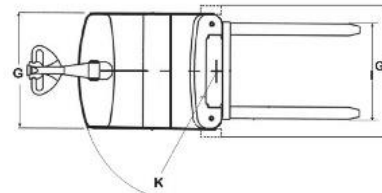
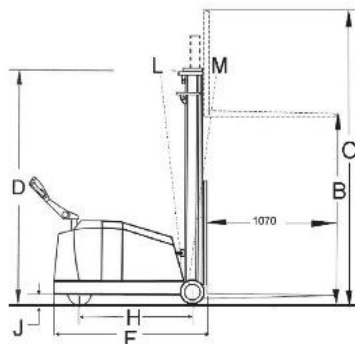

Due to continuous product improvement, specifications are subject to change without notice or obligation. Some systems and features shown are optional at extra cost.